

# HIRE & RENTAL

Volume 6 Number 1 1985  
Registered by Australia Post — Publication No. VBP3839

## AUSTRALASIA

OFFICIAL JOURNAL OF THE HIRE AND RENTAL ASSOCIATION OF AUSTRALIA.



**A  
REVOLUTION  
FOR THE  
HIRE INDUSTRY**

# How to win new friends in hire places.



Simple. Just stock the new Stihl FS 65 AVRE Brush Boss Brushcutter, the BG 60 AVE Airbroom, the HS 60 AVE Hedgetrimmer, or the 034 AVEQ

Chainsaw. Four powerful new profit generators from our 1985 range. See your Stihl dealer, or contact Stihl in your State.

**STIHL**<sup>®</sup>  
**№ 1 WORLDWIDE**  
*And here too, Boss!*

STPR 115/DYR

VICTORIA: Stihl Chain Saw (Aust.) Pty. Ltd. 2 Forbes Cl. SCORESBY. 3179. Tel: (03) 765 1455 NEW SOUTH WALES: Stihl Chain Saw (Aust.) Pty. Ltd. 180 Adderley St. AUBURN. 2144. Tel: (02) 647 2966 QUEENSLAND: Stihl Chain Saw (Aust.) Pty. Ltd. 35 Allison St. MAYNE. 4006. Tel: (07) 52 2021 SOUTH AUSTRALIA: Stihl Chain Saw (Aust.) Pty. Ltd. 394 Main North Rd. BLAIR ATHOL. 5084. Tel: (08) 260 3766 TASMANIA: Stihl Chain Saw (Aust.) Pty. Ltd. 210 Wellington St. LAUNCESTON. 7250. Tel: (003) 44 9522 WESTERN AUSTRALIA: W.A. Chain Saws (1980) Pty. Ltd. 108 Burswood Rd. VICTORIA PARK. 6100. Tel: (09) 361 5444 NORTHERN TERRITORY: Agserv Industries. 1059 Stuart Hwy. BERRIMAH. 5788. Tel: (089) 84 3577



Cover Photo:

**A REVOLUTION FOR THE HIRE INDUSTRY**

Pictured firing the first shot in the Insurance Revolution for the Hire Industry is Des. Whelan, Chairman of Directors, Hire and Rental Insurance Brokerage Pty. Ltd.

Pictured from left to right are fellow directors: Malcolm Barnett, Norman Peaceful, Desmond Whelan, John Kroeger, Brian Elms and Terence Lane. See story Page 4.



**OFFICIAL JOURNAL OF:**  
Hire & Rental Association  
of Australia

Published by:  
**RENTAL INDUSTRY PUBLICATIONS**  
A division of  
Brian M. Elms Pty Ltd (Inc. in Vic.)  
10 Manningham Road,  
Bulleen, 3105, Australia.

**EDITOR: Brian Elms**  
10 Manningham Road,  
Bulleen, 3105, Australia  
Telephone (03) 850 5878  
Telex 30625 (ME 1523)

**ADVERTISING & CORRESPONDENCE**  
to be directed to:  
Hire & Rental Australasia  
P.O. Box 136,  
Bulleen, 3105, Australia.

**DISTRIBUTION**  
Direct mail to major equipment hirers  
throughout Australia including the  
members of Hire & Rental Association  
of Australia.

**EDITORIAL**  
Editorial submissions are welcome and  
should reach our office by the 10th day  
of the month preceding the month of  
publication.

**ADVERTISING**  
Advertising copy, bromides,  
transparencies or colour separations  
should reach our office by the 10th day  
of the month preceding the month of  
publication.

**SUBSCRIPTION**  
Postage rate for each issue to:  
Australia: \$A1.50  
New Zealand:  
Seamail: \$A1.60  
Airmail: \$A2.20  
Other Countries:  
Seamail: \$A2.00  
Airmail: \$A3.75

## OUR INSURANCE BROKERAGE is now up and running

Hire and Rental Insurance Brokerage Pty. Ltd. (HARIB) is now fully operative. The HARIB Programme is a unique insurance programme which has been specifically designed for the Hire Industry.

It features:

- \* Wide insurance cover for hire stock/plant anywhere in Australia. It can even compliment your damage waiver;
- \* "Theft by Hirer" cover;
- \* Yes! It can also cover Marquees against storm damage;
- \* Cover for burglary, including in a locked yard;
- \* Public Risk Insurance at the right price, with the right cover;
- \* A unique motor vehicle Hire and Lease programme.

This insurance cover is now available at very attractive rates, but ONLY to members of the Hire and Rental Association of Australia. Members may also share in the profits of the Brokerage, for included in the HARIB Insurance Package is an option for members to purchase a share in the Brokerage.

Hire and Rental Insurance Brokerage Pty. Ltd. is administered by a board of six directors, four are hiremen and two Insurance professionals.

If you have any questions, or would like further details of the Programme, contact HARIB by phone in:

Melbourne: (03) 329 1244  
Brisbane: (07) 371 9188  
Adelaide: (08) 333 2444

Perth: (09) 322 4954  
Hobart: (003) 31 3005  
Sydney: (02) 635 9777

### Hire Association Directory

**Hire and Rental Association of Australia**  
-62 York Street,  
Sydney, 2000  
President: Ron Williams (03) 211 9488  
Secretary: Rolf Schufft (02) 290 0700

#### REGION 2

**The Hire Association of N.S.W.**  
P.O. Box 129, Beecroft, 2119  
President: Jim Brown (02) 525 3333  
Executive Director: Denise Layton  
(02) 848 9817

#### REGION 3

**Hire and Rental Association of Australia**  
- Victorian Region Ltd.  
P.O. Box 59, Forest Hill, 3131  
President: Brian Elms (03) 850 2316  
Secretary: Lois Ziebell (03) 877 5453

#### REGION 4

**Hire and Rental Association of Australia**  
- Queensland Region  
P.O. Box 3, Sandgate, 4017.  
President: Brian Telfer (07) 277 8566  
Secretary: Dorothy Verney (07) 269 9171

#### REGION 5

**Hire and Rental Association of Australia**  
- South Australian Region  
12 Pirie Street, Adelaide, 5000  
President: Pat Pearce (08) 272 5422  
Secretary: Frank Beecham (08) 212 4681

#### REGION 6

**Hire and Rental Association of Australia**  
- West Australian Region  
P.O. Box 569, Cloverdale, 6105.  
President: Peter Noske (09) 274 4395  
Secretary: Don Loxton (09) 451 9555

# A Revolution for the Hire Industry

An insurance plan especially designed for the industry at a price that won't hurt.

by Rob Goldman, Group Marketing Executive  
HIRE & RENTAL INSURANCE BROKERAGE PTY. LTD.

There's nothing new about people uniting for the common good. Indeed that's the basic concept behind associations and the insurance industry. Nor is there anything new about association endorsed insurance programs - they've existed for decades.

What is relatively new is an association forming their own insurance brokerage and that's what your association has now done!

History has been that members have found that getting the right cover has been either complicated or downright impossible. Let's face it, the insurance industry just didn't want to know you. Covers were either inappropriate or at a cost that took a sizeable chunk out of the pie. On an individual basis members do not have any great buying power but combined they are in a position of strength to negotiate far more favourable terms.

It is difficult to properly insure a hire operation from an insurance companies point of view. There are several problem areas. One is a special coverage is required to cover not only hire stocks while on the owner's premises but also anywhere in Australia whilst in the hirer's possession and during which time the owner has little or no control over his property. Another is the theft by hirer risk which is an area which insurers traditionally regard as "the cost of doing business". Then there are problems getting storm cover for marquees, burglary cover in a locked yard and insurers are afraid of the enormous exposures in the liability area. These were some of the major problems we had to solve and solve them we did!

A feasibility study was conducted to determine the insurance needs and claims experience of members. One member, in response to the survey, summed it up when he said, "I feel that the prices I am currently paying do not reflect the total lack of claims over the years I have conducted the hire business. Much of my plant is insured under inappropriate cover as no policy exists for the type of cover I require, e.g. all individual items with a value over \$1,000 are covered by a fleet motor vehicle policy when off the premises. This is not appropriate for concrete saws, rotary hoes, etc. and I am pleased that I have not had to test the extent that this

cover offers. I would hope that a separate rate structure would be devised for country operators and I'd prefer a rate based on a choice of low premiums and higher excess. Some of my existing policies overlap as no one policy covers all my requirements.

As a result of an excellent response to the survey, we were able to design a package that would meet the needs of the majority of the membership. Should the program not meet any specific requirements of an operation, we can modify the terms or tailor a "one-off" cover.

The Association Executive wanted a program that would specifically fit the hire industry, one that would take into consideration all of the risks - a comprehensive insurance for a diverse market. "We were not looking for the most inexpensive program, but one that suited the needs", said Brian Elms, President 1983-84 for Victorian Region. However, members will be pleased at the cost saving advantages that were achieved.

The policy covers and the exclusions have been specially designed to comply with that essential document of your business - the hire contract.

The establishment of the brokerage, which is owned by the Association, was a most positive step. Ignorance of hire operations was one flaw in the insurance industry but now Hire and Rental Insurance Brokerage Pty. Ltd. (HARIB) with offices established in all States, can offer protection for needs that are understood.

The program is only available to financial members of the Hire and Rental Association of Australia and insuring members have the option of purchasing a share at \$10.00. This then allows for a distribution of the profits to participating members by way of a dividend. Our profit share scheme is yet another benefit. H.A.R.I.B. has been properly constituted and complies with the Insurance (Agents and Brokers) Act 1984. The brokerage carries full protection for the membership in Professional Indemnity and Fidelity Guarantee covers.

## DO YOU FLY THE ASSOCIATION FLAG?



For the benefit of members the Hire and Rental Association of Australia has now produced it's own flag.

Distinctive and bright the 6'0" x 3'0" flag is yellow with the Association logo screen printed in black upon it.

Flags are available from the Association **now** at the cost of \$50 each including postage.

The Secretary  
Hire & Rental Association of Australia  
GPO Box 3968, Sydney, 2001.

Please supply ..... only Hire & Rental Association flags at cost \$50.00 each, including postage.

Please forward them to me at

.....  
.....  
.....  
.....

My cheque for \$ ..... is enclosed.

## A summary of the finest coverage available today for hire and rental operations

The package can automatically cater for both the small business and operations with turnovers of up to \$5 Million. Outside of these limits specially designed covers are offered within the program. The options available are:-

### Part 1

#### **FIRE AND SPECIFIED PERILS - ON PREMISES COVER:**

Covers the assets of your business such as buildings, hire stock, plant and equipment against damage by fire, lightning, impact, explosion, earthquake, aircraft, riots and strikes, malicious acts, storm, water (excluding flood) and sprinkler leakage.

#### **BURGLARY - ON PREMISES COVER:**

Loss or damage to hire stocks, plant and equipment whilst on your premises including a locked yard. You have a flexible choice of the sum insured and a unique method of risk rating has been devised.

#### **CONSEQUENTIAL LOSS, FIRE AND SPECIFIED PERILS:**

We can protect your business from financial hardship or ruin that often follows the events outlined in (1). The cover protects your business for a loss of profits for up to 12 months.

#### **OUTSIDE PREMISES WHILST ON HIRE OR LEASE**

##### **- ANYWHERE IN AUSTRALIA:**

Covers your hire stock and plant against damage or loss from fire, accidental damage, storm, malicious acts, burglary, earthquake and collision. A different approach has been devised in calculating the premium which results in considerable cost savings. For those that have "Damage Waiver" the cover has been designed to also compliment this.

#### **THEFT BY HIRER:**

Available to members who have a minimum of one year management experience and have good customer screening practices. Again a fresh approach has been taken resulting in an affordable and workable cover.

#### **BREAKAGE OF GLASS:**

Covers all internal and external glass including the cost of temporary security, signwriting and damage to frames.

#### **PUBLIC LIABILITY:**

Protects you for your liability arising from hire and rental activities, including sales, demonstration, importing and distribution and property ownership including tenants liability, goods sold or supplied, hoists, cranes and unregistered vehicles. This cover is available for an indemnity of \$1 Million or \$2 Million and higher limits can be granted.

#### **MONEY:**

Protects money in transit, on your premises or in the custody or proprietors or employees.

#### **INCOME PROTECTION:**

Any number of individuals involved in the business can be covered 24 hours a day for accident and/or illness with the benefits being payable for up to two years.

### Part 2

#### **A MOTOR VEHICLE - RENTAL/LEASING PROGRAM:**

Again we have made new inroads in the hire industry. Major rental/leasing companies (often through self insured programs) have been pooling their "numbers" resulting in lower rates which have given them a competitive edge over small independent operators. Our rates will help you compete! At this time the program is only available for trucks, vans, utilities, etc. up to 5 tons and is not available for sedans and vehicles used for interstate use (other than border town situations).

#### **WORKERS COMPENSATION, etc:**

Under separate policies we offer competitive terms for Workers Compensation and Motor insurance plus a market leading range of House, Contents and Boat Policies. We can also cater for any other form of business insurance for members and associated businesses.

The above is only a summary of the Hire and Rental Program. Our staff will be pleased to supply full details. Should you require advice on your insurance needs of any kind or how to reduce hazards and improve safety standards in your business, the services of our professional team are available throughout Australia at no obligation.

We believe that the service and coverages offered by HARIB and our most competitive premiums will be of long lasting benefit to the members. HARIB has and will continue to develop coverages that are unique and specially designed for the hire industry.

#### **A Nationwide Service:**

Hire and Rental Insurance Brokerage Pty. Ltd., incorporated in Victoria, offers its services Australia-wide through offices in every capital city. If at any time you wish to effect or review cover, simply contact any of our branch offices where our trained staff will be happy to make the arrangements.

**Head Office:** 24 Jeffcott St, West Melbourne 3003. Phone: (03) 329 1244, Telex: 31488

**New South Wales:** Suite B28, Market Plaza Bldg, Flemington Markets 2129. Phone: (02) 763 1488, Telex: 73215

**Queensland:** Suite 1, 2 Benson St, Toowong 4066 (PO Box 467). Phone: (07) 370 8568, Telex: 44715

**Western Australia:** Suite 11, 6-10 Douro Pl, West Perth 6005. Phone: (09) 322 4954, Telex: 94307

**South Australia:** Suite 21, 78 Hutt St, Adelaide 5000. Phone: (08) 223 7547, Telex: 87034

**Tasmania:** 80 Elizabeth St, Launceston 7250. Phone: (003) 31 3055



## WALLPAPER STEAMERS

Manufactured in Australia  
Specifically for the Hire Industry

#### **Features:**

- Stainless Steel Cylinder
- Automatic Reset Thermostat
- Low Water Level Protection Cut Out
- Stainless Steel Hand Plate
- 7lb Pressure Release Valve
- Aluminium Step By Step Instruction Plate

**Rental Industry Equipment Supplies**

PO Box 136 Bulleen 3105 Phone (03) 850 2316

● Write 520 on Reader Inquiry Card

# Unleaded Petrol

Answers to questions most frequently being asked



Unleaded petrol will be introduced to Australia in July this year, and already there are many questions being asked about it. To answer them, the Australian Institute of Petroleum Ltd. produced a leaflet, which we have reprinted, for the benefit of hirers who operate petrol-engined equipment.

## Why introduce a new grade of petrol?

Unleaded petrol (ULP) is needed because Federal and State governments have decided that all new petrol-engined cars, station wagons, panel vans and utilities manufactured on or after 1 January 1986 must be designed to run on that fuel.

(In New South Wales, the regulation extends to all other petrol-engined vehicles, including trucks and motor cycles. Elsewhere, that applies from 1 March 1988 for motor cycles and from 1 July 1988 for trucks. The NSW and Victorian regulations also cover late 1985-model vehicles designed and recommended by the manufacturer for use only with unleaded petrol.)

The main reason for this decision is to improve air quality in major cities, by reducing the amount of certain gases (carbon monoxide and hydrocarbons) in vehicle exhausts. Unleaded petrol is needed because catalyst technology will be used to achieve the required reduction in emission levels. Regulations specifying the new, lower emission limits apply to new cars from 1 January 1986.

Another reason for introducing unleaded petrol is to reduce emissions of lead compounds from vehicle exhausts.

## When will unleaded petrol be available?

It is a government requirement that unleaded petrol be available to the public nationally from 1 July 1985, and it will begin to appear at service stations from April 1985 onward.

## What will happen to super grade and standard grade petrol?

Super petrol will continue to be available nationally for many years, alongside the new unleaded petrol grade.

Standard petrol will go off the market when unleaded petrol is introduced. The storage, distribution and retail dispensing facilities now used for standard petrol will be cleaned out and switched over to unleaded petrol.

## Will existing vehicles be able to use unleaded petrol?

Many certainly will. It is expected that there will be plenty of publicity about which makes and models can run on unleaded petrol. Owners and drivers of these cars will be encouraged to switch to the new fuel.

However, most pre-1986 model vehicles will need to continue to operate on super petrol.

All motorists, including those who currently use standard petrol, should watch for – or seek – advice from vehicle manufacturers or motorists' organisation on whether or not to run their present vehicles on unleaded petrol.

## How will unleaded petrol differ from today's petrol?

It will be pale yellow in colour to distinguish it from the red-coloured super grade, and it will have an octane rating between those of super and standard.

	Octane No. (Research)
Super petrol	97
Unleaded petrol	91-93
Standard petrol	89 or 92

The decision by Federal and State governments that unleaded petrol of 92 octane should be introduced was based on a study which recognised the desirability of keeping costs down and of conserving oil. To make unleaded petrol of 97 octane would mean using significantly more crude oil in refineries, thereby raising costs. Government authorities determined the optimum octane rating for Australian unleaded petrol as 92, and engines of 1986 model vehicles will have compression ratios to match that octane rating.

## How will cars differ after 1985?

From 1 January 1986 new cars must comply with more stringent exhaust emission standards, and most manufacturers will meet the new standards by fitting catalytic converters to exhaust systems. (Naturally, pre-1986 model vehicles which are switched over to unleaded petrol operation will not need to have catalytic converters fitted to them.)

Catalytic converters change most of the carbon monoxide and hydrocarbons in engine exhausts into carbon dioxide and water vapour. They are intended to last the life of the vehicle and should need no maintenance. However, catalytic converters would be rendered ineffective by lead compounds in petrol; therefore, it will be an offence to use leaded petrol in a car designed for unleaded petrol.

The new generation of cars will carry UNLEADED PETROL ONLY labels near petrol caps, and will have narrow fill pipes – too narrow to receive the nozzles on leaded petrol pump hoses.

## How will motorists know that unleaded petrol is available?

From early in 1985 there will be a good deal of publicity about the advent of unleaded petrol in the middle of the year.

The first 1986 model vehicles, designed to run on unleaded petrol, are likely to be released in the second half of 1985. Their narrow fill pipes, labels near petrol caps (and elsewhere) and vehicle operator manuals will all indicate unleaded petrol requirements.

Service station pumps for unleaded petrol will be clearly designated and will have the new, narrow nozzles fitted to their hoses.

## Will there be much risk of cars being 'misfuelled' at service stations?

To prevent 'misfuelling' of 1986 model and later cars, their fill pipes will take only the new, smaller nozzles to be fitted compulsorily and exclusively to unleaded petrol dispensing pumps.

Any attempt to put leaded petrol into such a car will be not only illegal but also dangerous – because fuel is certain to spurt back and spill.

Although it will be physically possible to serve unleaded petrol into a vehicle that should have super, pump labelling should make such an error extremely unlikely. If an error does happen, a top-up with super as soon as possible is advisable because the lower octane rating of unleaded petrol could cause harmful engine-knock ('pinging').

**What will be the effect on vehicle fuel consumption?**

In existing cars, if they can run satisfactorily on unleaded petrol and if they are switched over to that grade, there will be no change in fuel consumption.

It is not possible to generalise about how 1986 model cars will compare with current vehicles in fuel consumption because there will probably be so much variation between different makes and models. Overall, fuel consumption is unlikely to differ much from current levels.

**What about farmers and industrial consumers who don't buy petrol through service stations?**

They will need to have access to unleaded petrol as soon as they acquire 1986 model or later vehicles, because it will be legally compulsory and probably a vehicle warranty requirement to use only unleaded petrol in the new models designed to run on that fuel.

Complete segregation of unleaded petrol from leaded petrol, as at service stations, will be essential.

These direct buyers should consult with their petrol suppliers to make the most efficient supply, storage and dispensing arrangements.

**What fuel should be used in petrol generators, motor mowers, chain saws, etc.?**

Manufacturers will be issuing advice in relation to both new engines and those now operated on standard petrol. Many engines will be able to use unleaded petrol, but others will need super grade.

The important thing is to follow the maker's recommendation.

**Who's Who 1985**

Hire and Rental Association of Australia's Who's Who for 1985 is currently being compiled.

Was your Business correctly listed last year? Are the indexes correctly cross referenced? Have you listed your other branches?

If your entry requires amendment in our next edition, please enter the correct details on the form attached and return by mail to:

The Editor, Hire and Rental Australasia, P.O. Box 136, Bulleen, 3105.

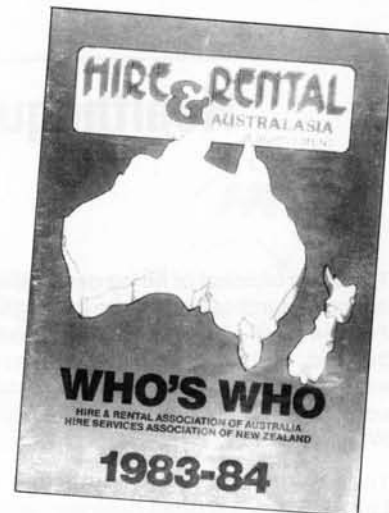

To The Editor,  
Hire & Rental Australasia.

Please amend our Who's Who entry as follows:

City/Town .....

Business Name .....

Street Address .....

Mailing Address ..... Postcode .....

Telephone (incl. area code) ..... (.....) .....

Name of Principal & Wife ..... (.....) .....

Service Codes .....

Members Index Listing .....

Business Name Index .....

Branches at:

City/Town ..... Phone ( ) .....

..... Phone ( ) .....

..... Phone ( ) .....

**UNLEADED PETROL  
"NO PROBLEM"  
FOR STIHL SAWS**

When asked about the likely effect of the introduction of unleaded petrol on the engines of Stihl products, Stihl's Director of Marketing Bob Donaldson said "We're advised that our products are compatible with unleaded fuels and will not create any problem in regard to extra wear. Depending on the availability of the unleaded petrol (appreciating that our products are used in some remote areas) we will be recommending the use of unleaded petrol for the end user's two-stroke mix".

**DON'T MISS THE BOAT!**

The 1985 HAA Convention Cruise is going to be a convention with a difference. Delegates from Canada, the USA, New Zealand and from most states of Australia will board P&O's Oriana in Sydney on July 30th for this years Convention Cruise. Oriana will cruise the Pacific islands before returning to Sydney August 9, 1985.

Delegates will learn from the "Nuts and Bolts" Seminars, Brainstorming sessions and by listening to selected Guest speakers during the cruise. There will be something for everyone at this Hire Convention, from the husband and wife partnership, to the Managers and Chairman of the Board.

When the day's business finishes, that's the time to join with family and friends to

enjoy the fun and use the facilities on board.

Your fare will include all shipboard meals, accommodation, entertainment, cinema, gymnasium, discos, cabaret, hospitality suite, cocktail parties, convention venues and top speakers at the seminars. The only things not provided are private drinks, personal shopping and shore excursions.

Will you be joining the delegates for this great Convention Cruise? Want more information?

Convention co-ordinator Arthur Staines has the cruise details, contact him NOW by writing to PO Box 126 East Brisbane, 4169, or telephone (07) 391 5666. You'll be glad you did!







# HITACHI RENTAL TOOLS THAT REALLY PERFORM



**Will take Kango type bits**

**DH50SA**  
Capacity  
Drill bit: 50 mm  
Core bit: 125 mm  
Power input: 1140 w  
Impact rate: 2300/min.  
Weight: 8.5 kg  
Length: 495 mm



**Will take Kango type bits**

**H55SA**  
Power input: 1140 w  
Impact rate: 1450/min.  
Weight: 9.5 kg  
Length: 560 mm



**DH38YB**  
Capacity  
Drill bit: 38 mm  
Core bit: 105 mm  
Impact rate: 2500  
Weight: 6.9 kg  
Length: 473 mm



**PH65A**  
Power input: 1500 w  
Impact rate: 1200/min.  
Weight: 15 kg  
Length: 664 mm



**H45SA**  
Power input: 1000 w  
Impact rate: 2700/min.  
Weight: 5.6 kg  
Length: 439 mm

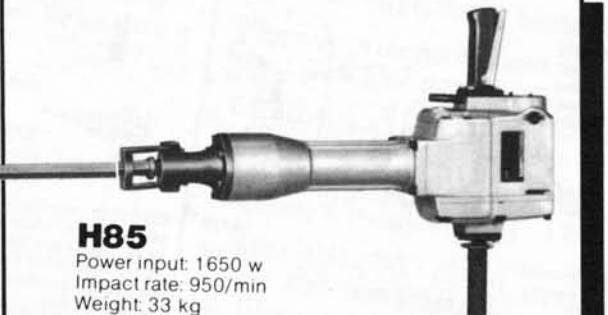

**H85**  
Power input: 1650 w  
Impact rate: 950/min  
Weight: 33 kg  
Length: 807 mm

**Use our Mail Order Service  
for Tools, Spares and Accessories**

**After Sales Service available in all States**

PO Box 136 Bulleen 3105.

10 Manningham Road, Bulleen.

Telephone (03) 850 2316

Brian M. Elms Pty. Ltd. (Inc. in Vic.) Trading as:

**RENTAL INDUSTRY EQUIPMENT SUPPLIES**

## Hitachi Proven Rental Tools For Every Application

**BLOWERS**  
PB-20 Vacuum/Blower with bag & nozzle **\$105**

PB-20 Vacuum/Blower, Bag & Nozzle ..... 105.00  
Freight & Handling ..... \$7.50 ea.

### CUT OFF MACHINES

C15FA Mitre Cutting Pre-set Lock-in table **\$447**

C10FA 255mm 2400w Mitre Cutting ..... 328.00  
C15FA 380mm 2400w Mitre Cutting ..... 447.00  
CC-12 305mm 2400w Cap. 100x100mm ..... 183.00  
CC-14 355mm 2400w Cap. 115x115mm ..... 212.00  
CC16SA 405mm 2400w Cap. 135x135mm ..... 260.00  
Freight & Handling ..... \$12.50 ea.  
CC12Y 305mm 2000w Cap. 100x100mm ..... 227.00  
Freight & Handling ..... \$12.50 ea.

### DRILLS

DMT-16 2-Speed, 16mm Chuck **\$141**

DG-6 6.5mm 320w Pistol Grip ..... 79.00  
Freight & Handling ..... \$5.00 ea.  
DMT13A 13mm 700w DHandle 2speed ..... 108.00  
DMT-16 16mm 900w DHandle 2speed ..... 141.00  
Freight & Handling ..... \$7.50 ea.

### HAMMER DRILLS

DH50SA Rotary Hammer Will take Kango bits **\$439**

VRT22A 22mm 650w Rotary 2speed ..... 345.00  
Freight & Handling ..... \$7.50 ea.  
DH38YB 38mm 1000w Rotation Stop ..... 390.00  
Freight & Handling ..... \$10.00 ea.  
DH50SA 50mm 1140w Rotary Hammer ..... 439.00  
Freight & Handling ..... \$12.50 ea.

### IMPACT DRILLS

VTP13A Industrial 2-speed D-Handle **\$120**

VTP-13 13mm 700w Pistol Grip ..... 108.00  
VTP-13A 13mm 700w D-Handle ..... 120.00  
Freight & Handling ..... \$5.00

### DISC GRINDERS

PDU-230 Heavy Duty Ind. Cut Off Flange **\$107**

PDP-100C 100mm 500w ..... 53.00  
Freight & Handling ..... \$4.00 ea.  
PDU-125A 125mm 1200w Spindle Lock ..... 93.00  
Freight & Handling ..... \$5.00 ea.  
PDU-230 230mm 2300w ..... 107.00  
Freight & Handling ..... \$7.50 ea.

### TRAIGHT GRINDERS

BLU-4 Industrial Double Insulated **\$207**

BLU-4 125mm 700w ..... 207.00  
Freight & Handling ..... \$7.50 ea.

### HAMMERS

PH-65A Demolition Hammer in a Steel Case **\$484**

H-85 Demo. Hammer, Weight 33kg ..... 845.00  
Freight & Handling ..... \$20.00 ea.  
PH-65A Demo. Hammer, Weight 15kg ..... 484.00  
Freight & Handling ..... \$15.00 ea.  
H55SA Can use Kango bits 9.5kg ..... 419.00  
H45SA Hammer 1000w Weight 5.7kg ..... 307.00  
Freight & Handling ..... \$10.00 ea.

Warranty and After Sales Service available in all States.

## Hitachi Proven Rental Tools For Every Application

### HAND SHEARS

C-16 Incl. Spare Incl. spare pair of cutters **\$200**

C-16 Cuts Steel 1.6mm AWG No14 ..... 200.00  
Freight & Handling ..... \$7.50 ea.

### NIBBLERS

LA-12 Deep Throated Incl. Spare Punch & Die **\$244**

LA-12 Cuts Steel 1.2mm AWG No17 ..... 244.00  
Freight & Handling ..... \$7.50 ea.

### JIG SAWS

JH-60A Cuts 60mm deep Single speed **\$113**

JH-60A 3200SPM 380w One Speed ..... 113.00  
Freight & Handling ..... \$5.00 ea.

### SABRE SAWS

CR-10V Stroke 26mm Cuts Pipe to 100mm **\$175**

CR-10V Univ. blade attachment ..... 175.00  
Freight & Handling ..... \$7.50 ea.

### CHAIN SAWS

CS-280A 280mm (11") Manual oil feed **\$120**

CS-280A Bar size 280mm 1140w ..... 120.00  
Freight & Handling ..... \$5.00

### PLANERS

F-20A 6mm Rebate Cutting Width 82mm **\$67**

F-20A 82mm Cut, Weight 2.5kg ..... 67.00  
F-30A 92mm Cut, 25mm Rebate ..... 124.00  
Freight & Handling ..... \$5.00 ea.

### ROUTERS

TR-12 1600w Plunge Type **\$132**

TR-12 2hp Plunge Type, 12mm Bit ..... 132.00  
TR-6 Laminare Trimmer 6.5mm Bit ..... 90.00  
Freight & Handling ..... \$5.00 ea.

### SANDERS

SAT-180 2 speed Sander/Polisher **\$109**

S00-110 Dustless Orbital 110mm ..... 122.00  
SAT-180 Sander/Polisher 180mm ..... 109.00  
SB-75 Dustless Belt 76x533mm ..... 108.00  
SB-110 Dustless Belt 110x620mm ..... 170.00  
SAY-150A Rotary Orbital 150mm ..... 127.00  
Freight & Handling ..... \$7.50

Warranty and After Sales Service available in all States.

## SPECIALS

ALL PRICES INCLUDE SALES TAX  
Valid for month of issue only (or while stocks last)

Please Supply .....

Consign by Road/Rail/Air, charge freight to us.

or

Add freight & handling costs \$ .....

Name: .....

Address: .....

Our cheque is enclosed \$ .....

## WELDING ELECTRODES

Now available in  
**10 PACKS**

Yes! 10 Rods plastic wrapped and carded

Ideal for sale with each Welder Rental

General purpose Electrodes for welding mild steel in all positions. Approved by Lloyds Register of Shipping. Approved in accordance with ASME Boiler and Pressure Vessel Codes U.S.A.

**2.5mm Size 78¢ ea.**

Freight and Handling  
60 packs \$7.50

**3.2mm Size 98¢ ea.**

Handling and Freight  
60 packs \$10

## INDUSTRIAL QUALITY PORTABLE SANDING BELTS

Full Range of Grits and Sizes

Example 75 x 533 (3 x 21)  
75 x 610 (3 x 24)  
100 x 610 (4 x 24)  
63 x 406 Sandcat.

**83¢ ea**

Wrapped in 10's boxed in 50's  
Assortments Accepted

Handling & Freight  
Per box of 50, \$5ea.

## Hitachi Proven Rental Tools For Every Application

### CIRCULAR SAWS

PSU-9 2000w Max. Cut 84mm **\$128**

PSU-7 190mm 1700w 65mm Cut ..... 109.00  
PSU-9 235mm 2000w 84mm Cut ..... 128.00  
Freight & Handling ..... \$7.50

### SCREW DRIVERS

W-6VA Reversible, Variable Speed **\$100**

W-6VA Variable Speed, Reversible ..... 100.00  
Freight & Handling ..... \$5.00

### IMPACT WENCHES

WH-16 1/2" Square Drive, Reversible **\$172**

WH-16 1700rpm, 440w, Reversible ..... 172.00  
Freight & Handling ..... \$7.50

### CORDLESS TOOLS

DV-10D Impact Drill Reversible, 2-speed **\$150**

DRC-10 Rev. Drill, Incl. charger ..... 122.00  
DVI10D Impact Drill Incl. charger ..... 150.00  
Freight & Handling ..... \$7.50

Warranty and After Sales Service available in all States.

## FLASHING AMBER LAMPS

With Mounting Brackets  
(Nil Batteries Included)  
Fits 2 x 6v Batteries

**\$12<sup>ea</sup>**

Freight & Handling  
Box of 10 \$7.50

## EXTENSION LEADS EXTRA HEAVY DUTY

15 Metre x 10 Amp **\$11.79**  
15 Metre x 15 Amp **\$16.25**

Freight and Handling  
Lots of 3 \$5.00

30 Metre x 10 Amp **\$19.25**  
30 Metre x 15 Amp **\$28.00**

Freight and Handling  
Lots of 3 \$7.50

## Simister WALLPAPER STEAMERS

- \* Stainless Steel Tank & Pan
- \* Detailed Instruction Plate Attached
- \* Bright & Attractive In Appearance
- \* A Proven Rental Unit

**\$340**

Freight & Handling \$10

## LAMBSWOOL BONNETS

First Quality

7" **\$2.40<sup>ea</sup>**

9" **\$3.60<sup>ea</sup>**

## Job Lot 2nds

Ideal for Rental Use

## 8" Diameter

Fits 7/8" Dimple Pad

**\$1.69<sup>ea</sup>**

Freight & Handling  
Lots 25 \$4

## PRECUT FLOOR SANDING PAPERS

cut to fit

HIRETECH

& CLARKE

MACHINES

24, 40, 60, 80, 100, 120 grit  
Assortments Accepted

**89¢<sup>ea</sup>**

Freight & Handling  
50 Sheet Pack \$7.50ea

**STIHL**  
Prices Rise  
**5%**  
1st April 1985

Buy now before  
PRICES RISE!

Full range of STIHL EQUIPMENT stocked

## PHONE FOR QUOTES

Cutquicks & Chain Saws  
Brush Cutters & Earth Augers  
Power Tools  
Short Motors & Long Motors  
Guide Bars  
Loop & Roll Chain  
Spare parts & Accessories

## This Months Specials

O8S Short Motors **\$264ea.**  
Handling & Freight \$5.00ea.

O8S Changeover Powerheads

To fit:

Earth Augers \$378ea.

Borers \$378ea.

Core Drills \$378ea.

Cut Quicks \$324ea.

Chain Saws (nsc) \$324ea.

Handling & Freight \$7.50ea.

## Genuine Stihl Spares

Full ranged stocked  
Competitively Priced  
Compare these items

O8S Cylinder & Piston \$81ea.

O8S Clutch(complete) \$17ea.

Handling & Freight \$1.50ea.

O8S Diaphragm Kits \$7.20ea.

O8S Starter Springs \$3.40ea.

Handling & Freight 60¢ ea.

## Genuine Stihl Chain Loops

Picco & 3/8x.063 chain

Just 21¢ Per drive link

e.g. Chain for 17" O8S Saw,

66 Drive link loop \$13.86ea.

Chain for Stihl 010AV

44 Drive link loop \$9.24ea.

Handling & Freight \$2.00ea.

Stihl 404x.063 chain

Just 23¢ per drive link

e.g. Chain for 17" O8S saw

60 Drive link loop \$13.80ea.

Handling & Freight \$2.00ea.

## T.C.T. Cutters

improve performance of

**Stihl Auger Bits**

(All sizes available)

To suite 250mm (9.8") auger

TCT Cutter Blade \$50ea.

TCT Drill Point \$41ea.

Handling & Freight \$2.00ea.

PO Box 136 Bulleen 3105. 10 Manningham Road, Bulleen. Telephone (03) 850 2316

Brian M. Elms Pty. Ltd. (Inc. in Vic.) Trading as:  
**RENTAL INDUSTRY EQUIPMENT SUPPLIES**



## Turn Renters into "Repeaters"



### Put an EEL™ on your team

Customers come back for easy-to-use equipment like this rugged, professional-quality Electric Eel® Model C. It quickly and easily clears tough stoppages in 3" to 10" lines up to 200' long. And its self-feeding action means custom-

ers never have to touch the patented dual cable while it's rotating. The handle folds to fit car boots, and the cable can be repaired or replaced fast and inexpensively.

Call or write today for a free Rental Information Kit with product details.

Phone: 559 5622



Electric Eel (Aust.)  
11 Carrington Rd.,  
Marrickville 2204

- Write 509 on Reader Inquiry Card

# FOR SALE HIRE BUSINESS

Hanks Hire Service  
Griffith NSW

Walk in - Walk out Deal  
Freehold Shop & Land  
Main Area of Town

Telephone: (069) 62 4876  
A.H.: (069) 62 1871

Write 117 on Reader Inquiry Card

## Briefly . . .

### New Zealand Hire Conference & Equipment Exhibition June 24-27 1985

The HSNZ Conference and Equipment Exhibition will be held at Paihia, in the Bay of Islands from Monday 24 June through to Thursday 27 June 1985. The venue being the T.H.C. Hotel at Waitangi. An important part of any Hire Convention is the Equipment Exhibition and early indications from suppliers indicates strong support again this year.

An invitation is extended to Australian hire people to attend this years conference. Suppliers interested to provide equipment for display in the Exhibition and hire people should contact HSNZ Secretary: Kelvin Strong, PO Box 12-013 Wellington North, Telephone (04) 736514 for details.

### Helen Berwick Retires

Popular party hire personality Mrs Helen Berwick has retired from the Industry.

Helen's long career in the party hire business spanned 27 years. For over 24 years Helen has worked with Jock McKechnie at Miller Bros. Hirings Pty. Ltd., Victoria's oldest party hire business, and a further 3 years with Abbey Rents (Australia) Pty. Ltd. when they amalgamated with Miller Bros. forming Australia's largest party hire business.

### New phone number for H&RANSW

Denise Layton, Executive Director, H&RANSW advises that her new telephone number is (02) 85 6800. This change is effective immediately.

The Association's Postal Address is unchanged, ie.:

PO Box 129  
Beecroft 2119

### Children's Cots

The Standards Association of Australia has published a new edition of the standard dealing with safety aspects of children's cots.

AS 2172, Cots for Household Use (Safety Requirements) was prepared in order to expand the scope of the previous edition to include costs which do not have dropsides as well as to review some of the design requirements.

The standard is intended to provide guidelines for manufacturers and purchasers so that potentially hazardous features of cot design and construction can be avoided.

The standard specifies dimensions, materials, construction and assembly, and requirements for accessories where these relate to the safe use of a cot. Strength and durability are established by performance tests. Information to be supplied to the purchaser regarding assembly, maintenance and selection of a suitable mattress is also specified.

Copies of AS 2172 can be purchased from any SAA office at a cost of \$9.20 plus \$1.50 postage and handling charge.

### Hiremen go it alone

Two well known industry personalities have got together to establish their own hire business. Adelaide Access Hire Pty. Ltd. has been established by Mick Young and Phil O'Connell and will operate from 12 Wellington Street, Glandore. 5037. Tel: (08) 297 4733. They plan to service Adelaide's expanding access market.

Noah was the first accountant in the Bible. . . He was floating a company while the rest of the world was in liquidation.



**P&O's  
ORIANA**



**HIRE & RENTAL ASSOCIATION OF AUSTRALIA  
14th INTERNATIONAL HIRE CONVENTION, 1985**

## "ALIVE '85" Convention Cruise.

10 nights at sea departing Sydney for South Pacific Islands

Tuesday, 30th July to Friday, 9th August, 1985

# DON'T

# MISS THE BOAT

Sail away with the large group of Hire and Rental people from Australia - New Zealand - Canada and U.S.A. already booked.

After 12 months or more at the helm of your business, grab the opportunity of relaxing on board our Convention Ship, while gathering information and inspiration at our 14th national gathering.

**Plan your family vacation around the Convention** - Provide them with the holiday of a lifetime while you attend the business meetings, talks and discussion groups. What other convention centres provide facilities for your family members' needs, and also enable you to join them immediately after each meeting?

**The Oriana is a floating luxury hotel - convention centre - holiday resort - casino - night club - duty free shopping arcade - sports club.**

You will travel **First Class** in cabins with private facilities at \$1685 (Aust) per adult (special rates for children) which is well below the listed price. In addition you will also have included at no extra cost - **Convention Registration - All Convention Cocktail Parties - All other Convention activities - Chance to win cruise for two drawn at our last function - Free Travel Insurance.**

**Bonus Air Travel with T.A.A.** from all Australian States to Sydney and return is subject to 40% discount for 3 to under 12 year old children.

**Suppliers** are invited to join us for the same fare, but with **Free Exhibition Space** for small equipment, supported by display material.

### Make your Reservation now:-

\$50 (Aust) per person until March, then:-  
Half the cruise fare by 20th March  
Balance of cruise fare be 20th May.



## OFFICIAL REGISTRATION FORM

**HIRE CONVENTION 1985 P&O CRUISE  
C/- P.O. BOX 126, EAST BRISBANE  
QUEENSLAND 4169 AUSTRALIA**

**14th INTERNATIONAL  
HIRE CONVENTION, 1985**

Company Name: .....

Address: .....

Phone - Business: ..... After hours: .....

TITLE SURNAME INITIALS and Date & Place NATIONALITY  
Mr., Mrs., Miss preferred first name of birth

.....  
.....  
.....  
.....

Deposit (A\$50.00 per person) \$50.00 X ..... persons = \$ .....  
**TOTAL OF CHEQUE HEREWITH**  
Payable to: "HIRE CONVENTION 1985 P&O CRUISE"

# ADVERTISING

## HOW MUCH TO INVEST?

by Neil Grayson

Reprinted by Courtesy Hire News

This question must be asked many times of the professional agency or 'in company' publicity department, or the owner-operator to his wife, or partner etc..

There is no concise answer, for each hire operation is different, governed by location, resources of the outlet and other factors which revolve around the term demographics.

### Budgeting

An advertising budget must be established by any hire company — a budget being a plan for the present and future operations. It must be compatible with hire income and provide a means of control over your operation, but it cannot remain too rigid, cannot be unalterable, and should contain a contingency fund for the unexpected advertising opportunities which may arise. Administering the budget is more or less routine but planning and carrying out the budget is most important.

### What on?

What do we spend our budget on? This has to be decided at the same time a budget is prepared — the obvious choices being, direct mail literature; newspapers; radio, TV; institutional i.e. club programmes, notice boards, etc.; telephone directories, hoardings, buses, novelty giveaways, shop signs and posters; price lists, cinema, sponsorship, public relations exercises; and sales representatives.

In calculating the money you need for advertising you need to identify who it will be aimed at — tradespeople, D.I.Y./Homeowners, new customers, past customers. And what about promoting your business to your existing customers?

### 'Special' Features

A word of warning — don't let the advertising representatives plan your budget for you — you give them a figure, they'll try and stretch it a little, quote them the number of ads. you want per week or month, they'll offer you an alternative 'which will give you better coverage . . . and only costs another \$X'. Another favourite tack is we are doing a special feature on the hire industry, all your competitors will be taking space, how much will you want?!!' This can double any existing budget you may have carefully calculated. One of our local papers has scheduled a 'Hire Feature' every three to four weeks throughout the year!

### Common Sense

The philosophy of not cutting advertising expenditure to improve profits always remains solid common sense. If you budget for \$X000 at the beginning of the year — spend it! If business drops, advertising is the easiest place to cut and it is the hardest place to prove you are wrong. If your plan was good at the beginning of the year it is good all the way through.

Many hire people I am sure do not work out an effective advertising programme, instead they advertise as the spirit moves them (or as the Americans put it the SWAG method — Scientific Wild Ass Guessing), or when they feel they "have to because things are down" or "when it can be afforded". This is too haphazard and more preferable is a logically planned advertising budget which is used effectively to give you more coverage and bring in prospects at a lower cost.

### P.R. — 'Free' Advertising

To diverse slightly many of us forget the value of 'free advertising' which we need not budget for — a medium which insufficient hire companies use — I mean of course newspaper articles, radio and television news spots. Many hire companies are selfish in this respect, they think the media will not use material if it is blatant advertising and therefore they are not prepared to re-phrase the article or material so that it can be used to the benefit of the hire industry as a whole rather than just their own company.

To continue with this line of thought, when considering this 'free advertising' place yourself not as the reader but as an ally to these media in serving their readers and listeners, not forgetting technically, journalistically and morally, that advertisers are not entitled to preferential treatment. What interests the media? Ask yourself what interests you as a reader, read very carefully your local papers, listen intently to the radio and watch and listen to the local TV. How can you adapt your news items into their language? Are they interested in awards being won, human interest, record productivity or sales, business expansion, charitable contributions? My own company had several hundred dollars worth of flower seeds (no, not for growing my own plant) which we decided to offer to any charitable organisation for fund raising. A brief 40 word report was sent to six local newspapers, all of whom printed it mentioning our name in every case, the cost to us was \$2 for the stamps. The seeds would have been scrapped or given away in any case. That \$2 bought us some goodwill and exposed our name to many thousands of readers.

### Percentage of Income

This is a popular method of establishing a budget and is usually based on industry averages or what the hire man and woman has spent in the past for advertising. It is based on the premise that advertising results from and is paid for by hire, while actually hire income results from advertising. The method is simple to use and many use it through sheer force of habit. One main question is whether or not to base the percentage on the previous year's figures or the pro-

jected income. Between 1% and 4% appears to be the norm on this basis.

#### Units of Hire

Specify an amount 'per box of apples', 'per car' or 'per hire contract' to be spent on advertising. If you write 5000 contracts and elect a figure of 50¢ per contract your budget would be \$2500.

#### What Can I Afford?

Look at your financial statement and relate advertising expenditure either to profits or assets. Being too conservative however may not yield enough money to accomplish the task and will leave the budget to chance.

#### Task Method

Define the task you want your money to perform. Determine the type and quantity of advertising and then estimate cost. In this way you build up your budget rather than setting a figure and then breaking it down. Other methods include copying your competitors if you can find out details; or the arbitrary (seat of pants) method where you say 'we will spend \$X000'; and finally, the '... or bust' method where every dollar you can get your hands on goes for advertising in probably a final bid to bring in the customers.

#### Future Methods

Maybe with the current onslaught of computers we shall see a new method of budgeting advertising expenditure evolving. Possibly your present information records are sufficient to show up weak areas which need beefing up and it may be possible therefore to be more selective and allocate part of your budget to this area and cut back on the more successful areas.

Which is best? Everyone has different ways to accomplish the same task and it is best to use the method which is most comfortable for you.

One final point — shouldn't those foolish enough to be offering discounts include this in their advertising budget? After all it is being used to promote extra customers and get them to come to you rather than your competitors!

Advertising alone will not cure any hire ills you may have, but it is as important as vitamins are to human growth. Are you suffering from malnutrition?

## the **integer hire system** has been designed especially for your business

- \* Control all items
- \* Hire contracts
- \* Direct invoicing
- \* Correct prices & discounts
- \* Industry accounting
- \* Word Processing

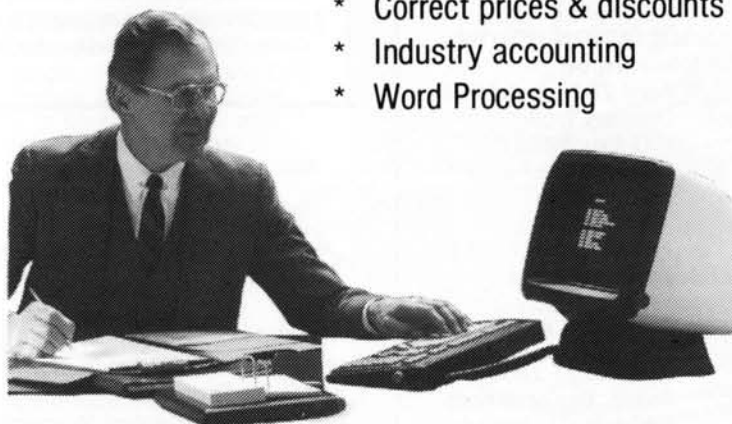

**Solve your problems tomorrow  
TALK TO US TODAY**

**integer  
computing  
pty. ltd.**

124 Albert Road  
South Melbourne  
Victoria 3205

**6995555**

Write 120 on Reader Inquiry Card

### **NEW REVERSIBLE VIBRO PLATE — DPU 2430**

WACKER AUSTRALIA PTY. LTD. has recently included in its selling program the new hydraulically reversible vibration plate — model DPU 2430.

The open base plate (300 mm wide X 700 mm long) is a self-cleaning design and is made of a wear-resistant nodular cast iron with rounded outline to guarantee long service life.

The application for this machine is obvious: Long and narrow trenches where no other plate would fit, and where the use of a rammer would be uneconomical, is the ideal application for this machine. The advantage of having a forward and reverse infinitely variable speed on up to 25 m per minute, and a compaction depth of up to 400 mm, gives you a compaction area of 450 m<sup>2</sup> per hour. The centrifugal force is 24 kN



or 2400 kP. The operating weight of the machine is 138 kg, and it is driven by an air-cooled single-cylinder 4-stroke Farymann diesel engine, model K 54, having a piston displacement of 242 cm<sup>3</sup>, delivering power of 3.5 kW (4.75 HP).

For further information  
**Write 32 on Reader Inquiry Card.**

## COMING EVENTS

### Hire Association of NSW Principals Seminar

**Date:** March 20 1985  
**Venue:** Sebel Town House  
Elizabeth Bay  
**Contact:** Denise Layton  
PO Box 129  
Beecroft 2119  
Tel: (02) 85 6800.

### HIRE ASSOCIATION SOUTH AFRICA Convention

**Date:** April 28-May 2 1985  
**Contact:** Duncan Trollip  
P O Box 39887  
Bramley, Transvall  
South Africa

### Hire Services Association New Zealand Conference & Equip. Exhibition

**Date:** June 24-27 1985  
**Venue:** Paihia, Bay of Islands  
THC Hotel at Waitangi  
**Contact:** Kelvin Strong  
PO Box 12-013  
Wellington North  
Tel: (03) 736514

### HAA Convention Cruise

**Date:** July 30-August 9 1985  
**Venue:** P&O Oriana  
Cruising Sydney,  
Noumea, Isle of Pines,  
Lautoka, Sydney  
**Contact:** Arthur Staines  
P O Box 126  
East Brisbane, 4169  
Tel: (07) 391 5666

### CRA Convention

**Date:** October 15-17, 1985.  
**Venue:** Las Vegas  
**Contact:** CRA 216 N.East St,  
Woodland,  
California 95695

### HAA Convention & Equipment Exhibition

**Date:** August 20-23, 1986  
**Venue:** Hilton International  
Hotel, Morphettville  
Racecourse Function  
Centre, Adelaide  
**Contact:** Richard Steven Hire  
Pty. Ltd.,  
2 Seacombe Road,  
Darlington, SA. 5047  
Tel: (08) 296 1001

## CYCLONE SCAFFOLDING WINS STAMP DUTY DECISION

Cyclone Scaffolding Pty. Ltd., whose business is the hiring of scaffolding, is not liable for Queensland stamp duty on amounts charged ADDITIONAL to the actual hiring fee. Charges referred to as additional, were delivery, labour, cleaning and repair of the scaffolding, insurance and stamp duty.

In a majority decision, the Queensland Supreme Court held that the additional charges were not received by the company "for or in relation to the use of

goods" from its rental business, within the meaning of section 35B of the Queensland Stamp Act.

It held that scaffolding, when being transported, erected, cleaned, repaired, or insured was not being "used" and the additional charges were not received in relation to its use.

Following the decision stamp duty does not have to be paid by Cyclone Scaffolding Pty. Ltd. on any of the additional charges.

## AIR BROOM MAKES QUICK CLEAN-UP

A useful machine for cleaning and maintenance operations is the new Stihl BG60 Air Broom, a motor-driven, hand-held blower designed for quick and efficient removal of debris, leaves, grass cuttings, loose dust and dirt from pavements, factory floors, lawns, parking areas and similar large expanses.

The BG60's light weight at 4kg, ergonomic design and single lever control make it easy to operate and transport.

The 19.8cc two-stroke motor enables the BG60 to deliver 365 cu ft of air a minute, at a velocity of 102ft per sec at 6300rpm. It will operate for 45 minutes at full throttle on each tankful of fuel.

Anti-vibration mountings and electronic ignition are standard.

For further information

Write 11 on Reader Inquiry Card



## Can You Hire Me a Freezer, Mate?

From what Don Neate, Paramount Hire, Cairns, tells us, next time you have a freezer hire, best find out exactly what is to be stored. Apparently, a guy came in from the bush, not a particularly respectable looking specimen, enquiring about long term hire on freezers.

Being the cautious man he is, Don quoted a bit on the high side, and enquired what was to be stored. The man informed him biological specimens, but not to worry, they would be in polystyrene boxes, in dry ice, but needed sub zero storage. Curiosity stirred, Don persisted as to what type

of biological specimens - marine, perhaps? Animal? Eventually, he pinned the description down, and was floored!

Apparently a good mate had died in a road accident, so they collected what they could, and they figured with the advances in cryogenics in the States, that in a few years they could either put the chap back together, or also cash in on the spares! Sounds like he had been smoking a bit too much of the herb superb!

Needless to say, Don didn't take the hire. Imagine explaining to your staff that there is a stiff in the freezer.

# SPECIALISED CONSTRUCTION EQUIPMENT, DIAMOND TOOLS & ASSOCIATED MACHINERY.

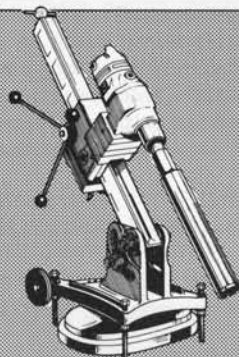

## DRILLING MACHINES

A complete range of diamond core drilling machines for all applications including electric, hydraulic and pneumatic powered. Robust construction.

## DEMBICON CONCRETE SAWS

Australia's most popular range—the Midget and D.C., manual and self propelled, 7 to 65 H.P. Robust and reliable, featuring the exclusive hydraulic raise and lower system.

## HAYASHI VIBRATORS AND FLEXIBLE PUMPS

Various engine options, latest electronic technology delivers superior performance.

## DEMBICON BRICK SAWS

Available in electric or petrol driven. Complete range of diamond blades available to suit any material.

## SANTO VIBRATION RAMMERS

Low maintenance, top quality, lightweight. Features include centrifugal clutch, oil lubrication system.

## NIKKO PORTABLE GENERATORS

Suit leisure or industrial use. Available in 1300 W, 1900 W and 2700 W. Easy maintenance, top quality.

## SANTO VIBRATION PLATE COMPACTORS

Equivalent to 6 ton road roller. Easy to use, low maintenance. A reliable performer.

## DEMBICON DIAMOND BLADES AND THIN WALL BITS

Manufacturers of Australia's largest range of diamond blades, and thin wall bits. Colour coded for easy replacement. Full service back up and advice.

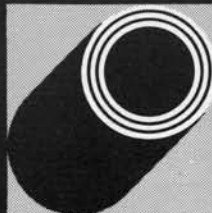
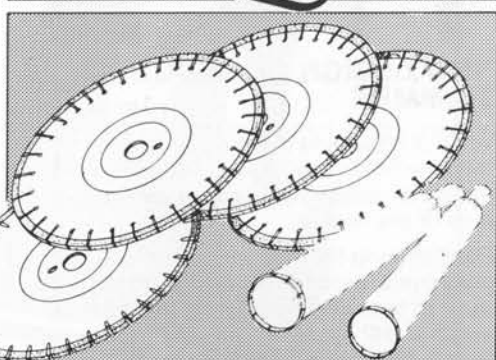
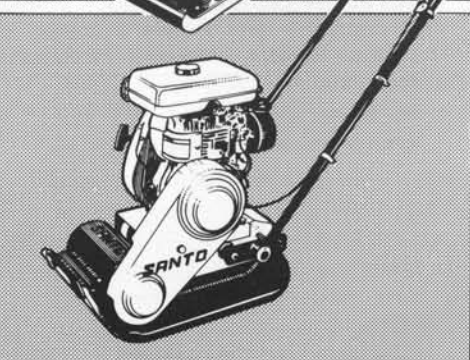
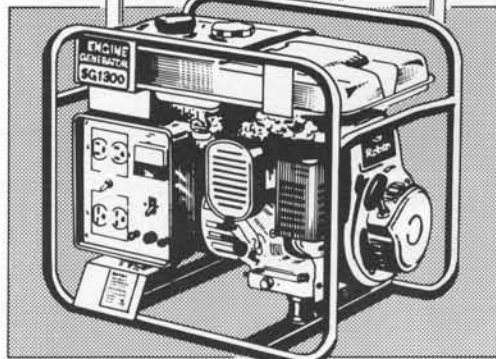
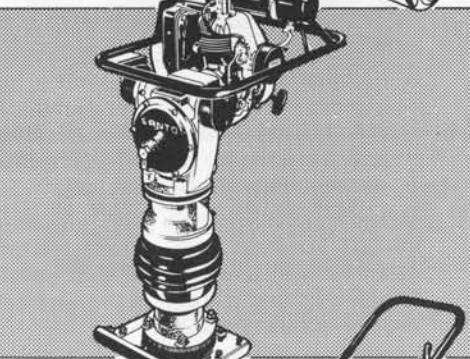
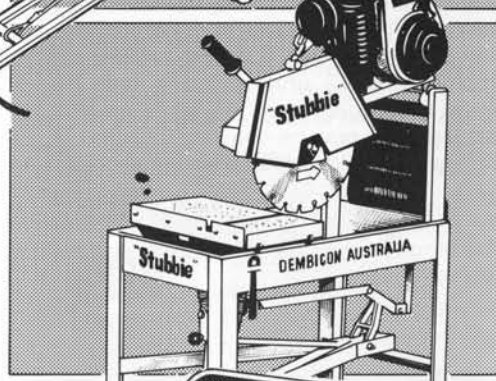
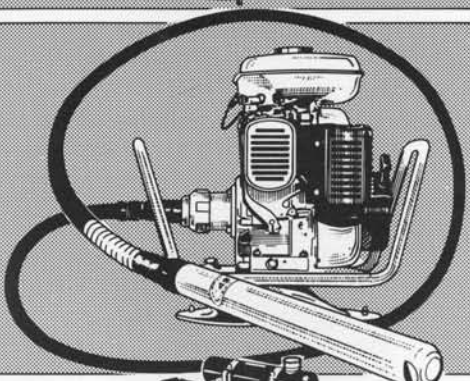
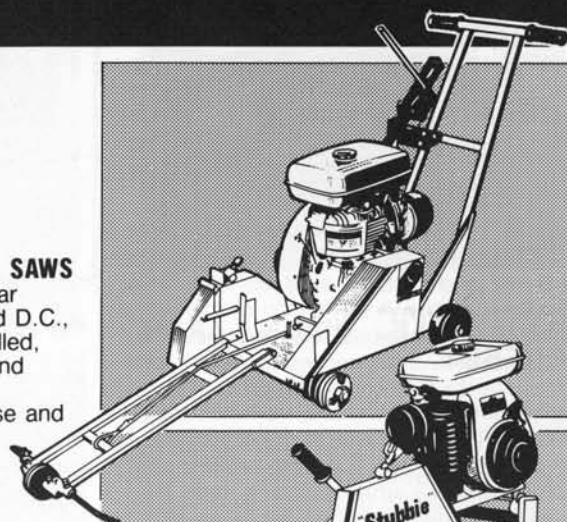

# DEMBICON AUST.

AUSTRALIA'S  
DIAMOND  
TOOL  
SPECIALISTS

**HEAD OFFICE**  
29 Kinkaid Avenue, North Plympton,  
South Australia 5037  
Tel. (08) 297 4022 Country Code (61)  
Telex: AA88857

**VICTORIA**  
11 Terang Avenue,  
East Burwood, VIC. 3151  
Telephone (03) 288 1700  
Telex AA36639

**NEW SOUTH WALES**  
Unit 2, 9 Works Place,  
Milperra, N.S.W. 2214  
Telephone (02) 772 3166  
(02) 772 3976  
Telex AA74954

**QUEENSLAND**  
154 Compton Road,  
Woodridge, QLD. 4114  
Telephone (07) 208 4249  
Telex AA145046



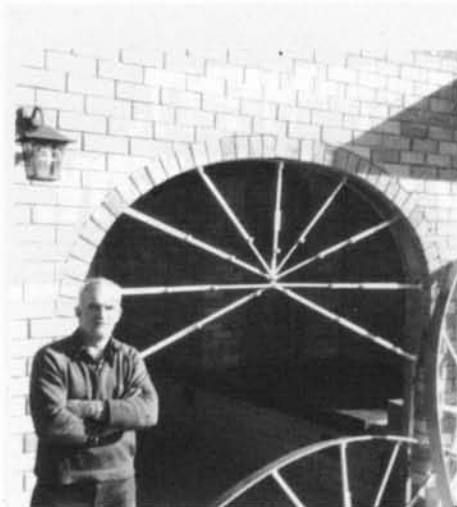

## ADJUSTABLE BRICK ARCH CENTRES

Archmould is an infinitely variable, fully reusable profile for use in the construction of brick arches. A simple archmould (comprising 12 units per set) may be used for standard arches, while several archmoulds may be coupled together in the construction of larger span arches.

Inventor and manufacturer of the Archmould Brick Arch Centre, Peter Dominguez is pictured beside one of his versatile units.

For further details:

Write 111 on Reader Inquiry Card



## NEW DESIGN OF HEDGE TRIMMER

Vertical mounting of the cutting blade on the new Stihl HS60 AVE Hedge Trimmer makes it easier to operate on the vertical face of the hedge.

For trimming the horizontal surface, the machine's ergonomic design makes it easy to turn and hold, while the 19.8 cc engine will operate in any position. Single-lever control makes starting and operation simple and safe, while anti-vibration mountings reduce operator fatigue. Electronic ignition means reliable running and easy starting.

The HS60 AVE has reciprocal cutters, and a blade lock for safety while starting and transporting the machine.

For further information.

Write 112 on Reader Inquiry Card

## SALES TAX REFUNDS NOW AVAILABLE ON RETREAD TYRES PURCHASED SINCE JUNE 1983

The Tax Office has lost a long legal battle over sales tax on retread tyres. The legal fight, taken up by the AACC on behalf of retread-tyre manufacturers and dealers, centred on the definition of what constituted a manufactured product – the criteria for application of sales tax.

The Full Federal Court determined that the Tax Commissioner's Interpretation of the Sales Tax Act was invalid, and it

has defined what constitutes a manufactured product. This decision has prevented the spread of sales tax to other items such as re-conditioned car engines, which are repaired in some way but are not manufactured items. As a result of this decision, "On customer instruction, any retread wholesaler could apply for refund of tax paid since June 1983" a Federal Government spokesman has stated.

## "D.C. Solenoid – 2001 Series"

Australian Engine and Transmission Company have announced the release of the synchro-start D.C. Solenoid in Australia.

Designated the series 2001, it is an amazingly small and compact solenoid that provides a strong pull force of 80 newtons (18 lbs) at 25mm (1 inch) and a hold force of 180 newtons (40 lbs).

The 2001 Solenoid has been a feature of many well known engines including the Deutz, M.W.M., Perkins, Lister and G.M. Diesel Engines. The Solenoid is now a feature of Rolls Royce Diesel Engines and powers the shutdown system that prevents the engine from overspeeding.

The 2001 Solenoid can be furnished with screw or spade terminals in electrical grounded or ungrounded models. Also available are a number of mounting and plunger styles to meet a wide variety of installation requirements.

The series 2001 has many other features including operating in a wide ambient temperature range of -40°C (-40°F) to 121°C (250°C), corrosion resistant, weighs approximately 1.2 kg (2.6 lb), plated housing and mounting bracket, sealed against dirt and moisture, high temperature magnet wire insulation 200°C (390°F) and also has a Lloyds Register of shipping approval.

For further information:

Australian Engines Transmission Co.,

Tel: (09) 279 4511

or write 102 on Reader Inquiry Card.

## NEW RANGE OF PUMPS FROM LEYFLOW

JRA Power Systems Pty Limited, national distributors of LEYFLOW PUMPS, proudly introduce an entirely new range of pumps.

LEYFLOW self priming pumps are available in the following combinations:-

1. Kawasaki 3.4 h.p. engine with a 1½" standard pressure pump, capable of a maximum head of 34 metres and a maximum flow of 101 gallons per minute.
2. Kawasaki 5 h.p. engine and a 2" high volume pump, producing a maximum head of 34 metres with maximum pumping capacity of 122 gallons per minute.
3. Kawasaki 5 h.p. engine with a high pressure 1½" fire fighter pump, capable of a maximum head of 70 metres and a maximum flow of 102 gallons per minute.

The proven reliability of the Kawasaki air cooled, petrol, four stroke engine, coupled with the popular and reliable FINSBURY pump, assures the user of an efficient compact pump.

LEYFLOW pumps are readily available through the JRA Power Systems 250 strong dealer network throughout Australia.

For further information:

Write 110 on Reader Inquiry Card

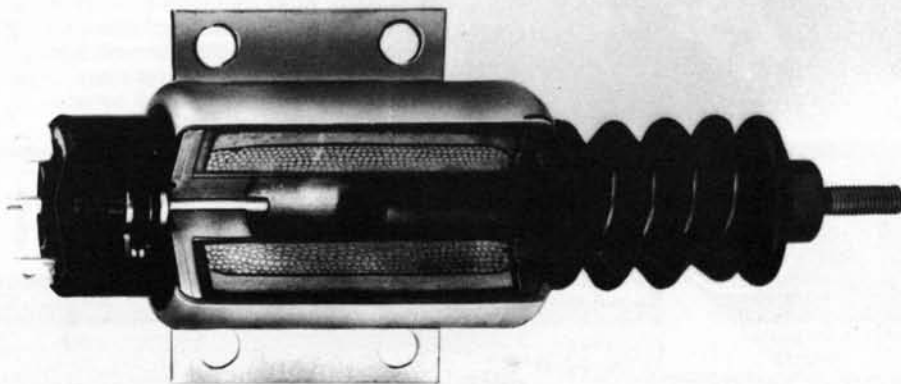

## Recognize these people?

These two people recently rented equipment from Carnegie Rental Centre. The two pictures were retrieved from Carnegie Rental's sophisticated video recording system which records date, time and customer on video tape during each hire transaction.

The customer below hired a Deutscher Mower on 10 September 1984. The other hired a Grinder and a Spray Gun on 12 September 1984.

Any reader who knows the name and current address of either of these people, please contact Mal Barnett on (03) 211 9488.



## THE STEAM MACHINE

Wallpaper removal is no longer a laborious job.

The Steam Machine removes wallpaper simply, with no fuss. No damage to the wall or room furnishings. It is easy to operate - no experience required. Concentrated steam dissolves the wallpaper adhesive, making the removal of wallpaper a fast and clean operation, leaving the wall ready for re-decoration.

Steam Machine is manufactured in Australia. Specifically for the Rental Industry, it has a larger aluminium plate, with step by step instructions, on the side of the machine. A stainless steel cylinder and handplate, with low level water protection cut out and automatic reset thermostat make it an ideal rental tool.

For further information:  
**Rental Industry Equipment Supplies**  
**Telephone: (03) 850 5878**

● Or write 505 on Reader Inquiry Card



# GET THE EDGE WITH W71A

the most advanced "pedestrian" operated edge roller"

Here's the 710mm vibrating edge roller that gives dynamic compaction, good balance and smooth directional changes. It's got everything for superior results with less operator fatigue.

Features include:

- SMOOTH TRANSMISSION. Hydrostatic drive coupled with fingertip controls
- BETTER COMPACTION. Infinitely variable
- BETTER BALANCE. Underslung counterweights reduce kick and operator fatigue
- LOWEST MAINTENANCE. Simplified transmission and vibrator drive, sealed bearings.

For Australia-wide service and spare parts contact:



A Division of  
 The ANI Corporation Limited  
 (Incorporated in NSW.)

N.S.W.: 1-5 Carter St, Lidcombe 2141. Phone: (02) 648 4088  
 VIC: 241-255 Browns Rd., Noble Park 3174. Phone: (03) 795 5111  
 QLD: Cnr. Ipswich & Grindle Rds., Rocklea 4106. Phone: (07) 275 1766  
 S.A.: 322 Grange Rd., Kidman Park 5025. Phone: (08) 356 7333  
 W.A.: 18 Wheeler St, Belmont 6104. Phone: (09) 277 1944

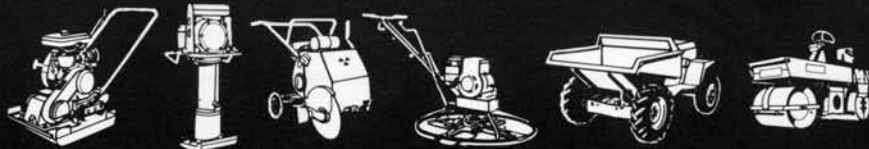

Write 113 on Reader Inquiry Card

ANI 359/CEN

# RIGA'L "DINGO"

Versatile, Economical, Low Maintenance, Super Loader

**Introducing the New Riga'l Universal Loader "Dingo",  
Especially Designed for Australian Conditions.**

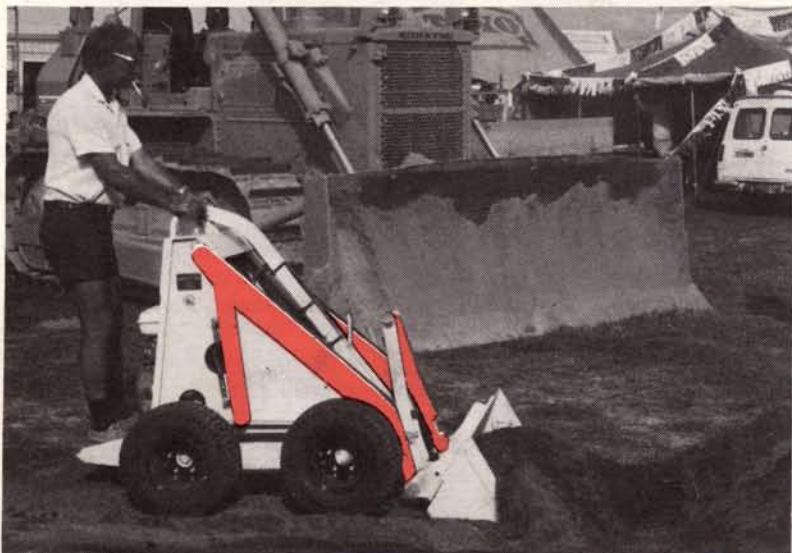

1. The four wheel drive Riga'l Dingo with Hydraulic Transmission is designed for rugged use, long life and low maintenance.
2. With its hydraulic power take-off implements can be removed and replaced quickly making the Mini Loader a versatile and profitable machine for the Hire Industry.
3. The Loader is designed to fit through an 820mm opening. It can also be fitted with additional wheels, which are available in 4", 6", 8" and dual Wheels.
4. The Riga'l "Dingo" with all its attachments means that one machine can be hired out as 7 separate Hire Uses, which means Hire productivity for the Hire Company, and better utilisation of hire equipment.

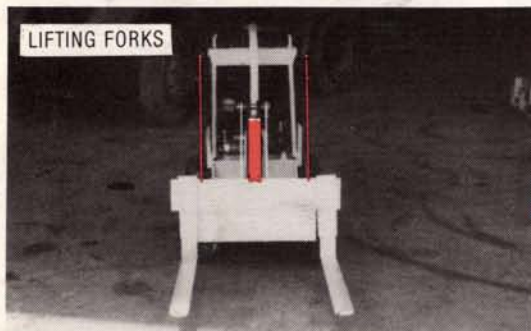

LIFTING FORKS

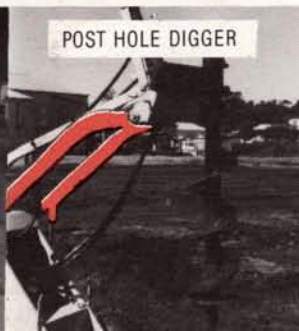

POST HOLE DIGGER

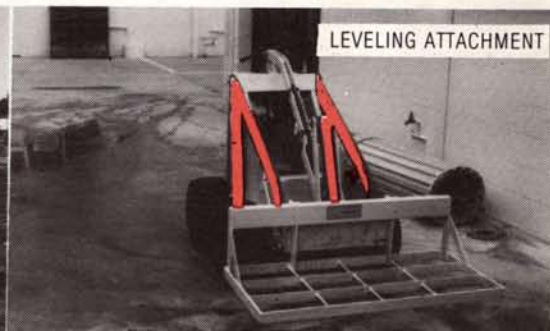

LEVELING ATTACHMENT

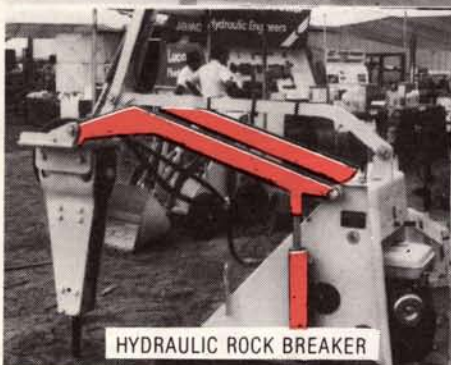

HYDRAULIC ROCK BREAKER

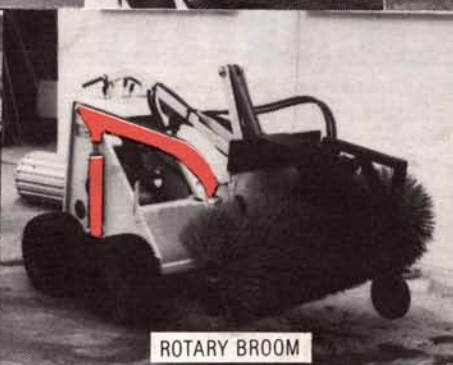

ROTARY BROOM



TRENCH DIGGER

#### Specifications:

Motor: 10 HP petrol driven Motor; Transmission: Dual Hydraulic Motors; Length: 1400mm (1950 with bucket); Width: 760mm; Height: 1200mm; Weight: 500kg; Lifting Capacity: 225kg; Lifting Height: 1700mm; Ground Speed: 5 k.p.h.

Riga'l "Dingo's" are sold throughout - Australia, U.S.A., Canada, United Kingdom, Saudia Arabia, New Zealand, Hawaii, Singapore, Hong Kong, Malaysia, Indonesia, Phillipines, Afghanistan and Mexico.

## RIGA'L UNIVERSAL LOADERS PTY. LTD.

P.O. Box 1026, Southport, Qld. Tel: (075) 32 9400

Contact us for Information on your local Riga'l Dealer

See us at all Major Shows

Write 101 on Reader Inquiry Card